



# Canberra Indian Myna Action Group



## PeeGee's Myna & Starling Trap Plans



[www.indianmynaactiongroup.org.au](http://www.indianmynaactiongroup.org.au)

President **Bill Handke** Email [president@indianmynaaction.org.au](mailto:president@indianmynaaction.org.au)

Not for Commercial use. Traps are not to be built and sold for commercial purpose unless approval is gained from the Canberra Indian Myna Action Group.

# Feeding and Containment Chamber Panels (flat view)

Construct as a single unit - this will be cut later on to form two separate chambers.

Cut a panel 64 squares long from a 900mm wide (36 squares wide) roll of Whites Wire Cage Mesh. Cut 4 panels (16 squares x 16 squares) which will form the ends of the two chambers.

Cut all these panels cleanly so there is no protruding wire bits (called selvage) - this will avoid scratches and cuts.

Bend the long panel at right angles at the 16th, 32nd and 48th square to form the four sides.

Bend the wire 'over the weld', and not away from the weld, to avoid the wire separating at the weld.

**Materials**

1. Whites Wire Cage Mesh (900mm wide x 25.4mm x 25.4mm mesh square x 1.25mm gauge wire mesh): a 5 metre roll makes one trap and a 10m roll makes three traps.

2. 2mm tie wire for latching clips

3. 140mm x 3.6mm cable ties (approx 170 required) - buy these from an electrical suppliers store if possible.

**SIDE PANEL** (one required)

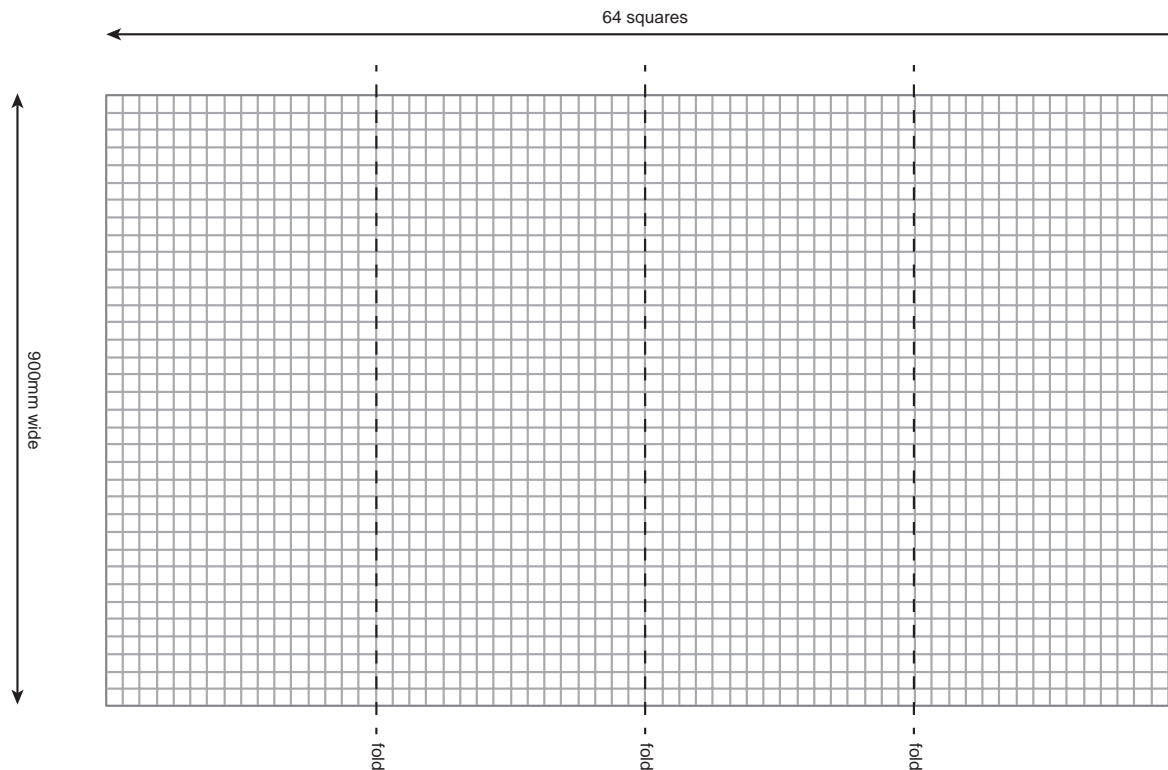

**END PANELS** (four required)

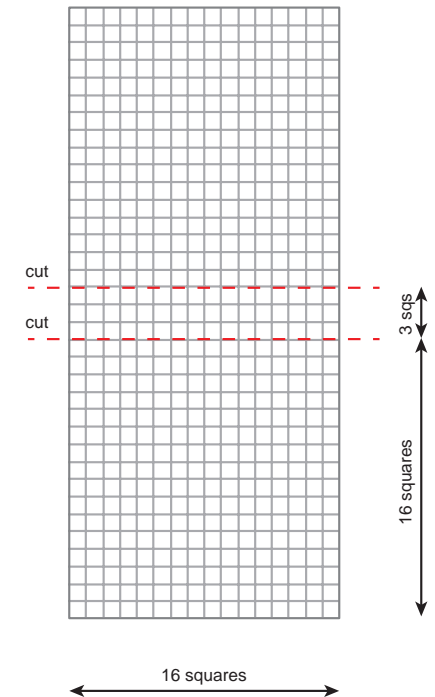

# Feeding and Containment Chamber Panels

Use cable ties to secure panels together, forming cage body. 140mm x 3.6mm black UV treated cable ties are easiest to work with.

Tie every other mesh square together, ie the 1st, 3rd, 5th, 7th etc.

**STEP 1**  
Bend at 16 squares to form sides and tie together with cable ties.

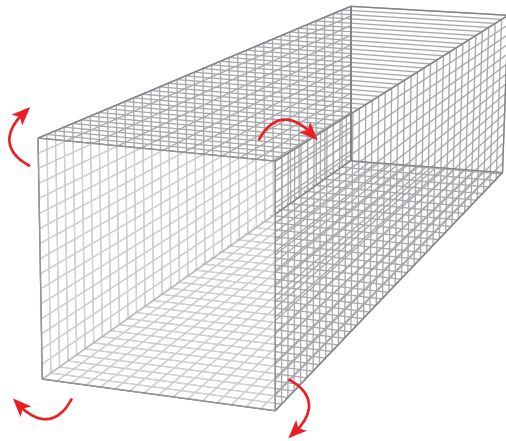

**STEP 2**  
Add both end panels and tie with cable ties every 2nd square.

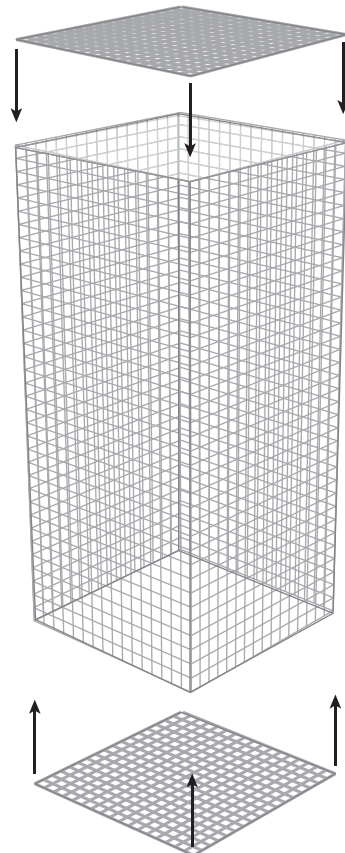

**STEP 3**  
Cut through cage starting after 12 squares from one end, creating two chambers. Cut the larger chamber back to 20 squares high. This makes it easier and quicker to euthanase the trapped birds.

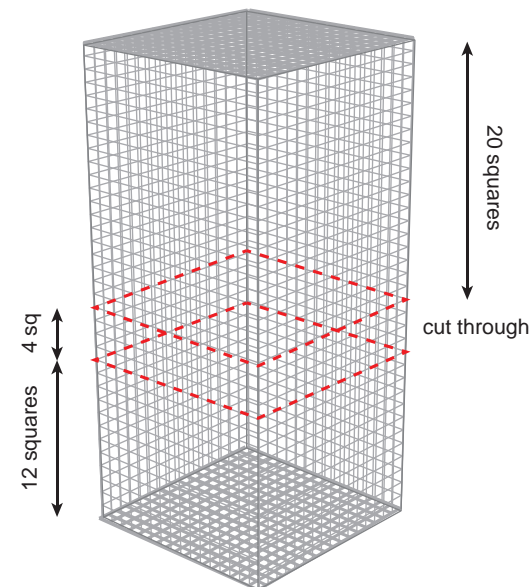

**STEP 4**  
Tie in the two remaining end panels to complete the chambers.

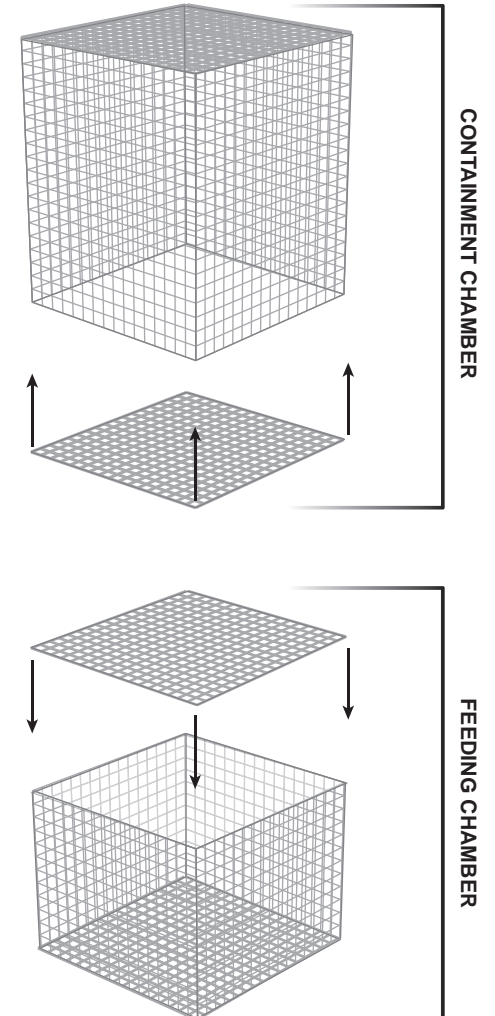

# Assembly of Valve Components

You will need to make three Valve components with the mesh wire. Cut the mesh at the places shown in red. Then follow the steps below to assemble.

## Valve Components

### A) Valve Body

12 x 9 squares with selvage removed from one end, sides clipped leaving two wires per side for tying.

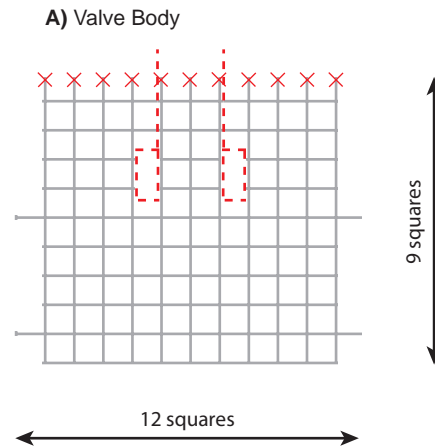

### B) Valve Cover

7 x 7 squares, clipped to 5 squares wide on six wires leaving two loose ends on each side for tying.

### B) Valve Cover

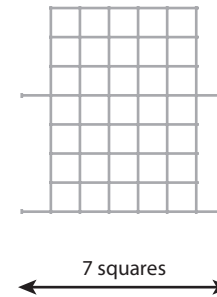

### C) Valve Base

### C) Valve Base

7 x 4 squares, clipped to 5 squares wide on two wires leaving two loose ends for tying.

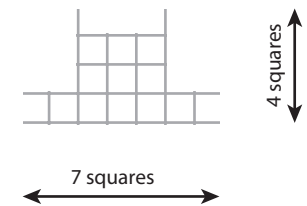

#### STEP 1

Shape Valve Body into a "U". Tie top together with the wire selvage at points shown to form a slight tunnel.

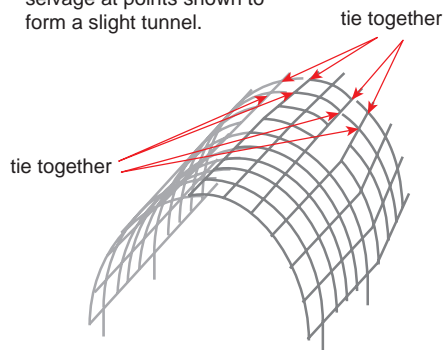

#### STEP 2

Use selvage by folding over and tying Valve Base to Valve Body at points shown below.

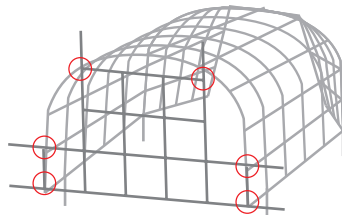

#### STEP 3

Bend Valve Cover at 45° on fold line. Bend wire over the weld, not away from weld.

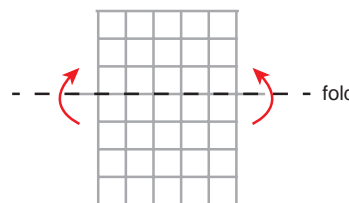

#### STEP 4

Tie the Valve Cover to the Valve Body using the selvage on the Valve Cover, positioning at 5 squares up from bottom edge of the Valve Body and 1 square in at the top.

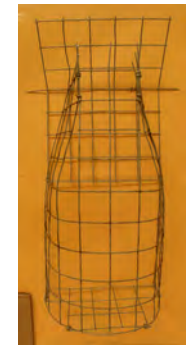
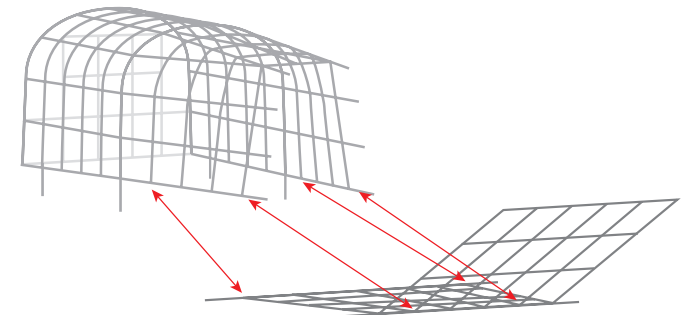

Finished Valve standing vertical.

# Assembly of Feeding Chamber Entrance & Door

Cut out D and E as shown (right). Then follow the steps below to assemble the Feeding Chamber Tunnels.

## Feeding Chamber Entrance Tunnels

You will need two.

**D)** 16 x 8 squares with selvage removed from one edge, sides clipped as shown. Cut out areas shown in red.

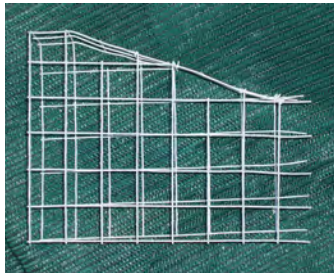

Finished Feeding Chamber Entrance Tunnel.

**D)** Feeding Chamber Entrance Tunnel (two required)

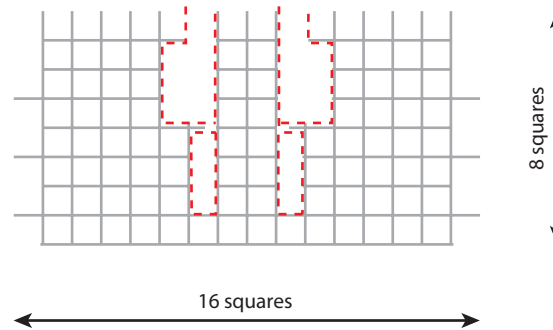

**E)** Door Panel

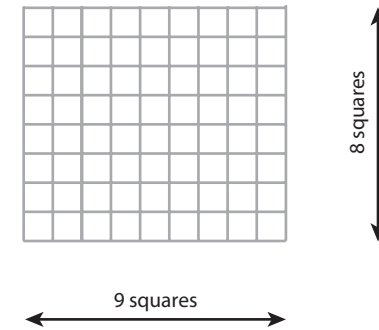

**STEP 1**  
Fold at right angles to form two sides and top of entrance.

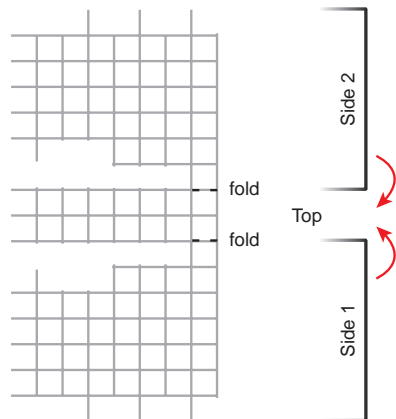

**STEP 2**  
Slightly bend down top to meet sides and tie selvage at marked points shown in red below.

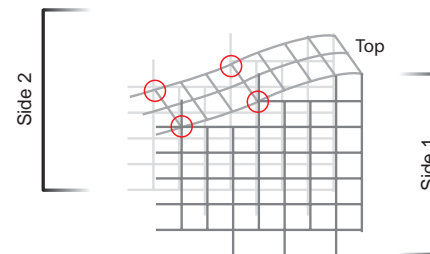

**STEP 3**  
Fold over one square on each side to stiffen the door.

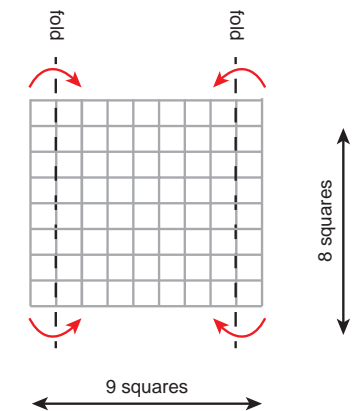



# Assembly of Feeding Chamber Component

Fit entrance tunnels at **A**, to the Chamber using cable ties.

Entrance Tunnel view from above

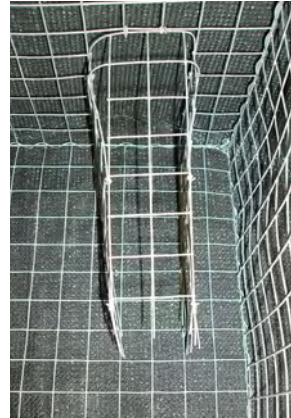

## Trap Components

### A) Entrance Tunnel

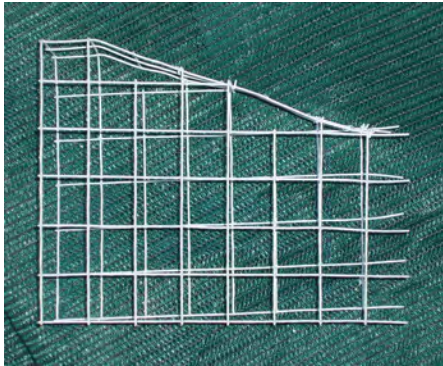

Entrance Tunnel view from outside of trap



#### STEP 1

Make two openings on adjacent sides of smaller Feeding Chamber (6 squares high x 3 squares wide), starting at two squares in from side edge. Push the 2 Entrance Tunnels into the Feeding Chamber through the hole cut at the back of the Feeding Chamber at **B** (see diagram right)

#### STEP 2

Fix the Entrance Tunnels inside the Feeding Chamber at **A**. Tie larger end (6 squares high) of the Entrance Tunnel to the Feeding Chamber wall with cable ties so that the smaller end sits inside the chamber itself. Use the selvage to tie base of tunnel to floor of the Feeding Chamber so it narrows inwards to end at 2 squares wide at the end. Use the last wire selvage from each side of tunnel to tie end to base.

#### STEP 3

Cut hole at **B**, 5 x 5 squares starting at six squares up from base and one square in from the side edge. Make sure not to cut the vertical wire, keeping the square complete.

## FEEDING CHAMBER

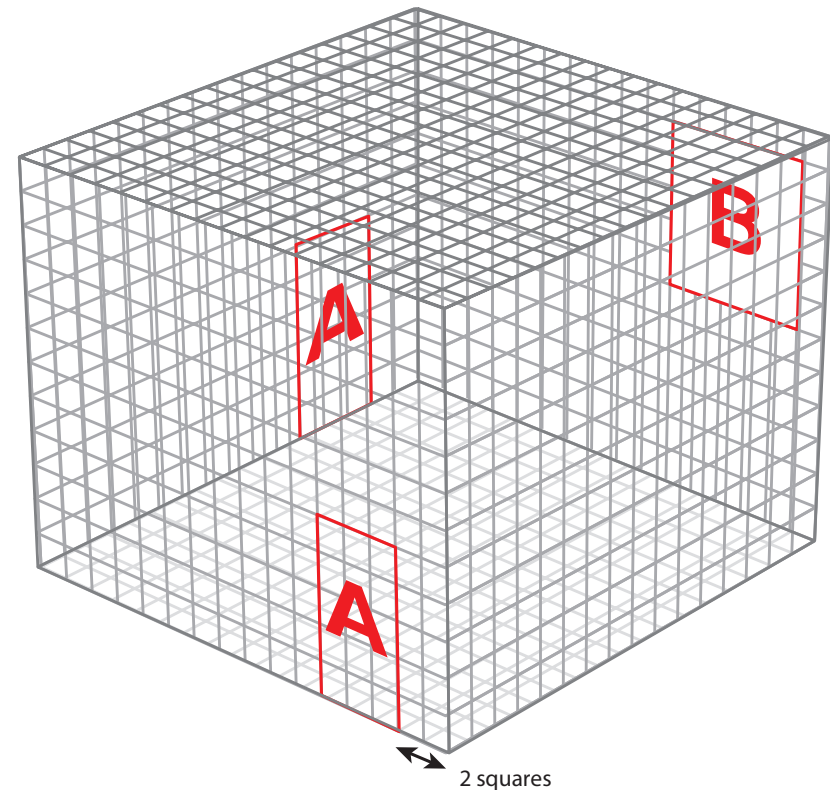

## Assembly of Containment Chamber Components

Fit non-return Valve at **B** and door at **C** to the Containment Chamber using cable ties.

Fasten latching clips onto service door (shown by black stars). Place a roost to sit in centre of cage, eight squares from top.

### Trap Components

#### B) Non Return Valve



#### STEP 1

Cut hole at **B**, 5 x 5 squares starting at six squares up from base and one square in from the side edge. Make sure not to cut the vertical wire, keeping the square complete. When both chambers are joined, these holes line up. Push the Valve into the Containment Chamber through hole shown at **B**.

#### STEP 2

Fix the Valve at **B** inside the Containment Chamber, with the cover end at the top, remembering to tie the selvage from the Valve Cover to the walls of the Containment Chamber.

#### C) Service Door

#### STEP 1

Cut one door opening at **C**, 6 x 5 squares starting three mesh squares in from the side and four mesh squares up from base. In cutting the hole for the door, leave half of the selvage on, which you then bend over to make a smooth edge all round the door opening. This will stop scratching you later. The door is hinged in the bottom and is to overlap the opening on two sides and the top by one square - to stop the trapped mynas from squeezing past to get out.

#### STEP 2

Hinges for door can be achieved by leaving ties slightly loose or by using netting wire clips. It is best to have the bottom corners of the door tied diagonally to the cage so that the door cannot slide sideways.

## CONTAINMENT CHAMBER

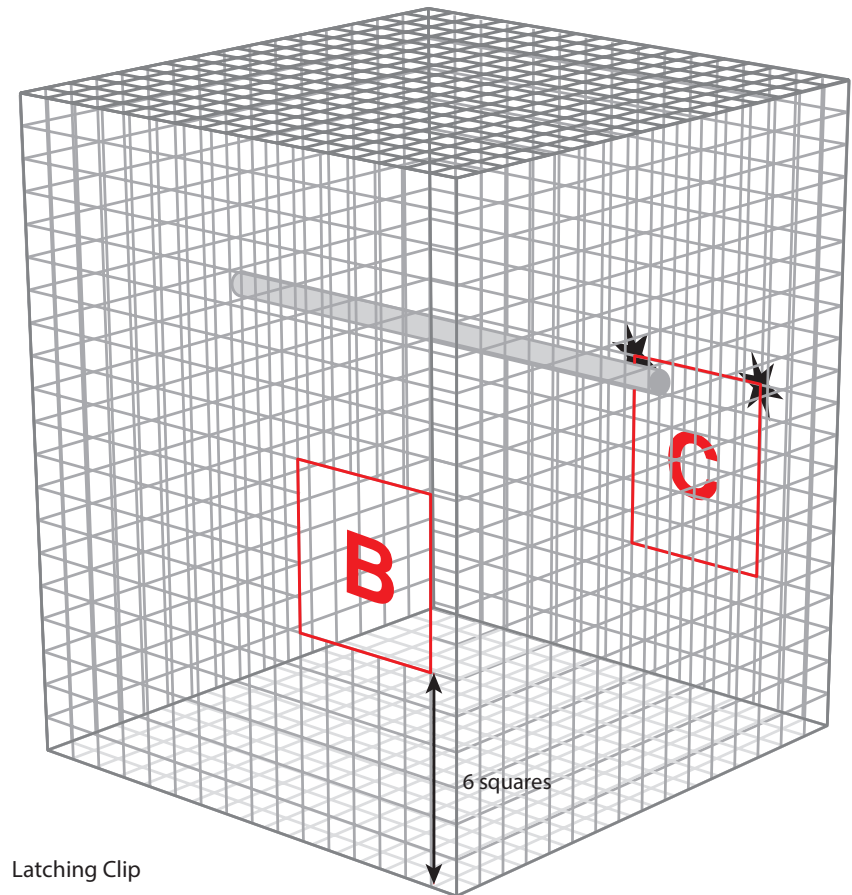

Latching Clip



Made from 2mm tie wire  
approx 130mm long (7 required)

# Final Assembly of Completed Trap

Bring together chambers, matching at **B** and fasten with latching clips shown at places with black stars. Place a roost to sit in centre of cage, eight squares from top.

To finish the trap, tie shade cloth over the top and partway down the sides of the Containment Chamber (150mm down sides), with a hole cut in the shade cloth above the Valve. This lets in light and encourages the mynas to move up through the Valve into the chamber.

## CONTAINMENT CHAMBER

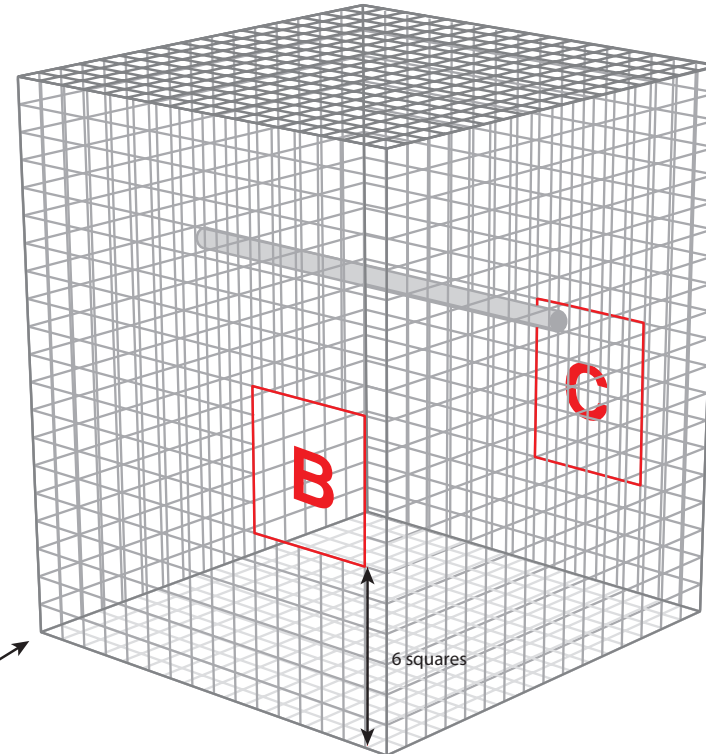

## FEEDING CHAMBER

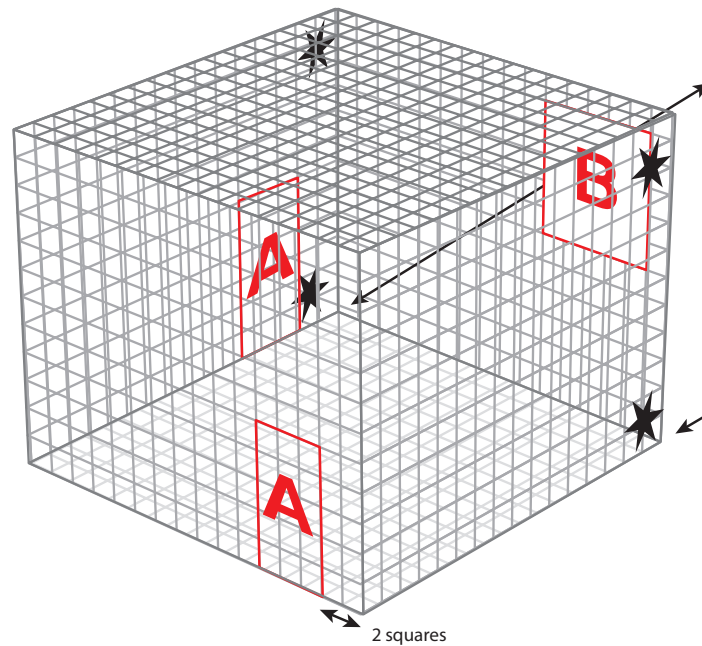

Made from 2mm tie wire  
approx 130mm long (7 required)